



Committing to the future

Pocket Guide Thermography

Nominal charge EUR 5,00

0981 7923/san/R/Q/07_2009

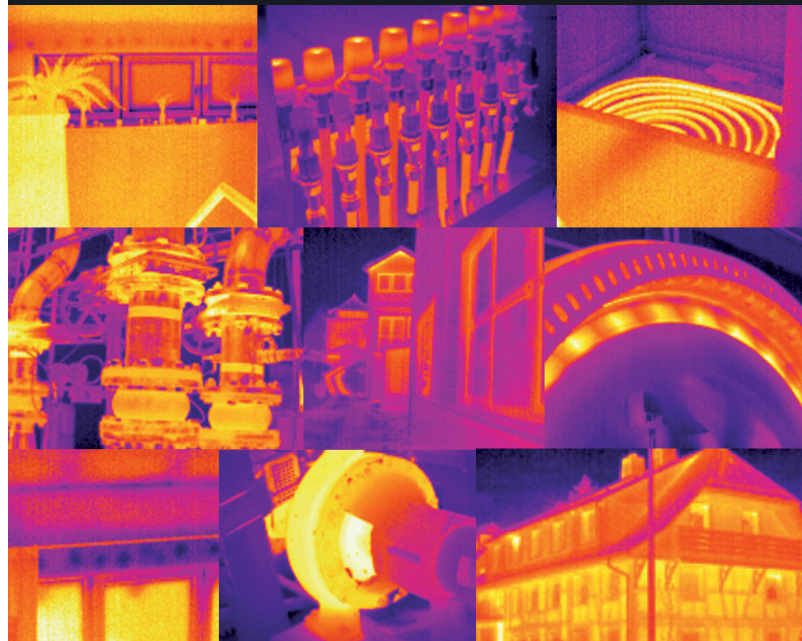

Theory – Practical Application – Tips & Tricks

You will find the contact details for our subsidiaries and agencies at www.testo.com

Foreword

Dear Testo customer,

"Pictures say more than a thousand words"

In times of rising energy prices and high costs for downtimes of machines, contactless temperature measurement has established itself both for the assessment of building efficiency and for industrial maintenance. However, thermography is not just thermography, and there are a few basic ground rules to be followed in contactless temperature measurement.

The "Pocket Guide Thermography" handbook was created by summarizing the questions raised by our customers on a day-to-day basis. Peppared with lots of interesting information and tips and tricks from practical measurement applications, this Pocket Guide is designed to offer you useful, practical help and support you in your daily work.

Have fun reading through it!



Daniel Auer,
Manager Product Group Infrared Measurement

Copyrights, guarantee and liability

The information put together in this Pocket Guide is protected by copyright. All rights belong exclusively to Testo AG. The contents and pictures may not be commercially reproduced, modified or used for purposes other than the defined user purpose without the prior written consent of Testo AG.

The information in this Pocket Guide has been produced with great care. Nevertheless, the information provided is not binding, and Testo AG reserves the right to make changes or additions. Testo AG therefore offers no guarantee for the correctness and completeness of the information provided. Liability, from whatever legal ground it may arise, is limited to damages caused by Testo AG or its vicarious agents or contractors through either intent, gross negligence or, in the case of a breach of material contractual obligations, minor negligence. In cases of minor negligence, the extent of liability of Testo AG is limited to the damages typical and predictable for comparable transactions of this nature. This does not affect compensation rights arising from guarantees or in accordance with the Product Liability Act.

Testo AG, September 2008

Contents

1. Theory of thermography	5
1.1 Emission, reflection, transmission	6
1.2 Measuring spot and measuring distance	13
2. Thermography in practice	16
2.1 Measuring object and measuring environment	16
2.2 Determining ϵ and RTC in practical applications	25
2.3 Sources of error in infrared measurement	28
2.4 The optimum conditions for infrared measurement	34
2.5 The perfect thermal image	35
3. Appendix	38
3.1 Glossary of thermography	38
3.2 Emissivity table	50
3.3 Testo recommends	52

1 Theory of thermography

Every object with a temperature above absolute zero (0 Kelvin = -273.15 °C) emits infrared radiation. This infrared radiation is invisible to the human eye.

As the physicist Max Planck proved as far back as 1900, there is a correlation between the temperature of a body and the intensity of the infrared radiation it emits.

A thermal imager measures the long-wave infrared radiation received within its field of view. From this it calculates the temperature of the object to be measured. The calculation factors in the emissivity (ϵ) of the surface of the measuring object and the compensation of the reflected temperature (RTC = reflected temperature compensation), both variables that can be set manually in the thermal imager.

Each pixel of the detector represents a thermal spot that is shown on the display as a false colour image (cf. "Measuring spot and measuring distance", p. 13).

Thermography (temperature measurement with a thermal imager) is a passive, contactless measuring method. The thermal image shows the temperature distribution on the surface of an object. For this reason, you cannot look into or even through objects with a thermal imager.

1.1 Emission, reflection, transmission

The radiation recorded by the thermal imager consists of the emitted, reflected and transmitted long-wave infrared radiation emerging from the objects within the field of view of the thermal imager.

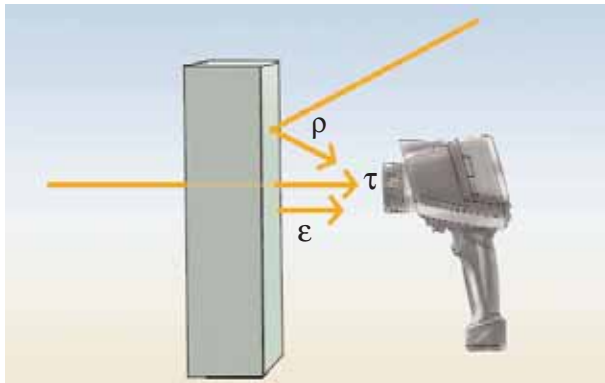

Figure 1.1: Emission, reflection and transmission



Emissivity (ϵ)

Emissivity (ϵ) is a measure of the ability of a material to emit (give off) infrared radiation.

- ϵ varies according to the surface properties, the material and, for some materials, also according to the temperature of the measuring object.

- Maximum emissivity: $\epsilon = 1$ ($\cong 100\%$) (cf. "black body radiators", p. 38). $\epsilon = 1$ never occurs in reality.
- Real bodies: $\epsilon < 1$, because real bodies also reflect and possibly transmit radiation.
- Many nonmetallic materials (e.g. PVC, concrete, organic substances) have high emissivity in the long-wave infrared range that is not dependent on the temperature ($\epsilon \approx 0.8$ to 0.95).
- Metals, particularly those with a shiny surface, have low emissivity that fluctuates with the temperature.
- ϵ can be set manually in the thermal imager.

Reflectance (ρ)

Reflectance (ρ) is a measure of the ability of a material to reflect infrared radiation.



- ρ depends on the surface properties, the temperature and the type of material.
- In general, smooth, polished surfaces reflect more strongly than rough, matt surfaces made of the same material.
- The temperature of the reflected radiation can be set manually in the thermal imager (RTC).
- In many measurement applications, the RTC corresponds to the ambient temperature. You can measure this using the testo 810 air thermometer, for example.
- The RTC can be determined using a Lambert radiator (cf. "Measurement of reflected temperature using an (improvised) Lambert radiator", p. 27).

- The angle of reflection of the reflected infrared radiation is always the same as the angle of incidence (cf. "specular reflection", p. 31).



Transmittance (τ)

Transmittance (τ) is a measure of the ability of a material to transmit (allow through) infrared radiation.

- τ depends on the type and thickness of the material.
- Most materials are not transmissive, i.e. permeable, to long-wave infrared radiation.

Kirchhoff's radiation law

The infrared radiation recorded by the thermal imager consists of:

- the radiation emitted by the measuring object;
- the reflection of ambient radiation and
- the transmission of radiation by the measuring object.

(Cf. Fig. 1.1, p. 6)

The sum of these parts is always taken to be 1 ($\cong 100\%$):

$$\epsilon + \rho + \tau = 1$$

As transmission rarely plays a role in practice, the transmission τ is omitted and the formula

$$\epsilon + \rho + \tau = 1$$

is simplified to

$$\epsilon + \rho = 1.$$

For thermography this means:

The lower the emissivity,

- ⇒ the higher the share of reflected infrared radiation,
- ⇒ the harder it is to take an accurate temperature measurement and
- ⇒ the more important it is that the reflected temperature compensation (RTC) is set correctly.

Correlation between emission and reflection

1. Measuring objects with high emissivity ($\epsilon \geq 0.8$):

- ⇒ have low reflectance (ρ): $\rho = 1 - \epsilon$.
- ⇒ Their temperature can be measured very easily with the thermal imager.

2. Measuring objects with average emissivity ($0.6 < \epsilon < 0.8$):

- ⇒ have average reflectance (ρ): $\rho = 1 - \epsilon$.
- ⇒ Their temperature can be measured easily with the thermal imager.

3. Measuring objects with low emissivity ($\epsilon \leq 0.6$)

- ⇒ have high reflectance (ρ): $\rho = 1 - \epsilon$.
- ⇒ Measuring the temperature with the thermal imager is possible, but you should examine the results very carefully.
- ⇒ Setting the reflected temperature compensation (RTC) correctly is essential, as it is a major factor in the temperature calculation.

Ensuring the emissivity setting is correct is particularly crucial where there are large differences in temperature between the measuring object and the measuring environment.

1. Where the temperature of the measuring object is higher than the ambient temperature (cf. heater shown in Fig. 1.2, p.11):
 - ⇒ Excessively high emissivity settings result in excessively low temperature readings (cf. imager 2).
 - ⇒ Excessively low emissivity settings result in excessively high temperature readings (cf. imager 1).

2. Where the temperature of the measuring object is lower than the ambient temperature (cf. door shown in Fig. 1.2, p.11):
 - ⇒ Excessively high emissivity settings result in excessively high temperature readings (cf. imager 2).
 - ⇒ Excessively low emissivity settings result in excessively low temperature readings (cf. imager 1).

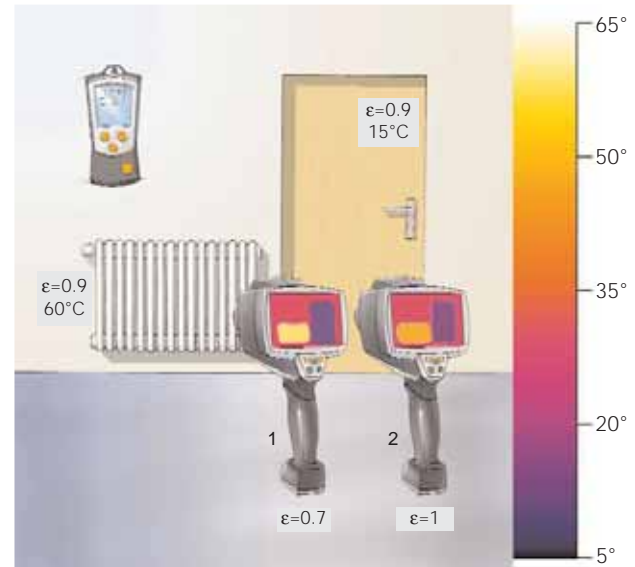

Figure 1.2: Effects of an incorrect emissivity setting on the temperature measurement

Please note: The greater the difference between the temperature of the measuring object and ambient temperature and the lower emissivity is, the greater the measuring errors are. These errors increase if the emissivity setting is incorrect.





- You can only ever measure the temperatures of the surfaces with a thermal imager; you cannot look into something or through something.
- Many materials such as glass that are transparent to the human eye are **not** transmissive (permeable) to long-wave infrared radiation (cf. "Measurements on glass", p. 30).
- Where necessary, remove any covers from the measuring object, otherwise the thermal imager will only measure the surface temperature of the cover.

Caution:

Always follow the operating instructions for the measuring object!

- The few transmissive materials include, for example, thin plastic sheets and germanium, the material from which the lens and the protection glass of a Testo thermal imager are made.
- If elements located underneath the surface affect the temperature distribution on the surface of the measuring object through conduction, structures of the internal design of the measuring object can often be identified on the thermal image. Nevertheless, the thermal imager only ever measures the surface temperature. An exact statement about the temperature values of elements within the measuring object is not possible.

1.2 Measuring spot and measuring distance

Three variables must be taken into account to determine the appropriate measuring distance and the maximum measuring object that is visible or measurable:

- the field of view (FOV);
- the smallest identifiable object (IFOV_{geo}) and
- the smallest measurable object/measuring spot (IFOV_{meas}).

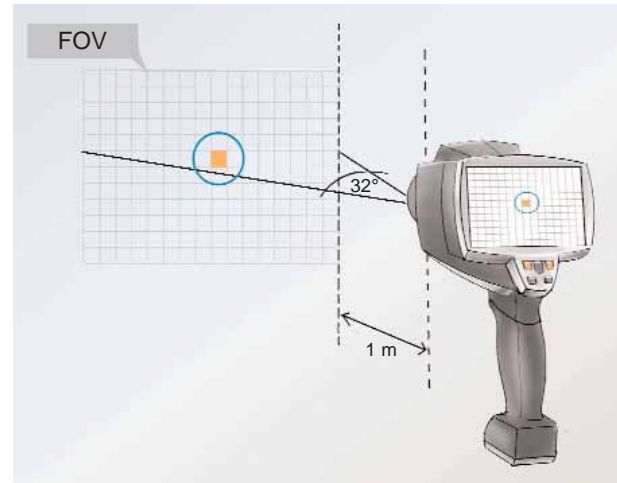

Figure 1.3: The field of view of the thermal imager

The field of view (FOV) of the thermal imager describes the area visible with the thermal imager (cf. Fig. 1.3, p. 13). It is determined by the lens used (e.g. 32° wide-angle lens – standard for testo 880, 12° telephoto lens is available as an accessory).



To get a large field of view, you should use a wide-angle lens.

In addition, you should know the specification for the smallest identifiable object (IFOV_{geo}) of your thermal imager. This defines the size of a pixel according to the distance.

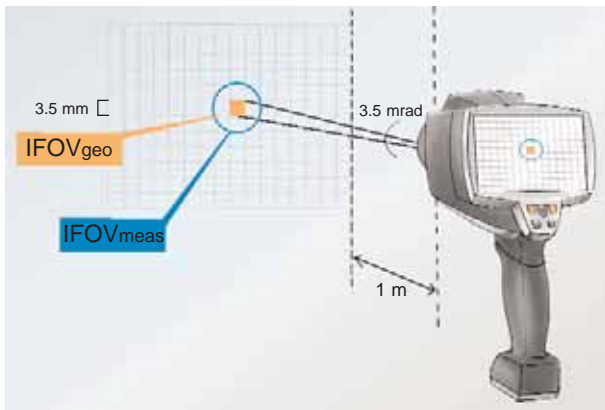

Figure 1.4: Field of view of an individual pixel

With a spatial resolution of the lens of 3.5 mrad and a measuring distance of 1 m, the smallest identifiable object (IFOV_{geo}) has an edge length of 3.5 mm and is shown on the display as a pixel (cf. Fig. 1.4, p. 14). To obtain a precise measurement, the measuring object should be 2 to 3 times larger than the smallest identifiable object (IFOV_{geo}).

The following rule of thumb therefore applies for the smallest measurable object (IFOV_{meas}):

$$\text{IFOV}_{\text{meas}} \approx 3 \times \text{IFOV}_{\text{geo}}$$

- For a good spatial resolution, you should use a telephoto lens.
- With the FOV calculator from Testo, you can calculate the values for FOV, IFOV_{meas} and IFOV_{geo} for different distances. Order this practical disc free of charge at www.testo.de/FOV or calculate your values online.



2 Thermography in practice

2.1 Measuring object and measuring environment

The measuring object



1. Material and emissivity

The surface of each material has a specific emissivity from which the amount of the infrared radiation emitted from the material that is

- reflected and
- emitted (radiated from the object itself) is derived.



2. Colour

The colour of a material has no noticeable effect on the long-wave infrared radiation emitted by the object to be measured when measuring the temperature with a thermal imager.

Dark surfaces absorb more short-wave infrared radiation than light surfaces and therefore heat up more quickly. However, the emitted infrared radiation depends on the temperature and not on the colour of the surface of the measuring object. A heater painted black, for example, emits exactly the same amount of long-wave infrared radiation as a heater painted white at the same temperature.



3. Surface of the measuring object

The properties of the surface of the measuring object play a crucial role in the measurement of temperature with a thermal imager. For the emissivity of the surface varies according to the structure of the surface, soiling or coating.

Structure of the surface

Smooth, shiny, reflective and/or polished surfaces generally have a slightly lower emissivity than matt, structured, rough, weathered and/or scratched surfaces of the same material. There are often specular reflections with extremely smooth surfaces (cf. "Specular reflection", p. 31).

Wetness, snow and hoarfrost on the surface

Water, snow and hoarfrost have relatively high emissivities (approx. $0.85 < \epsilon < 0.96$), so measurement of these substances is generally unproblematic. However, you must bear in mind that the temperature of the measuring object can be distorted by natural coatings of this kind. Wetness cools the surface of measuring object as it evaporates and snow has good insulating properties. Hoarfrost usually does not form a sealed surface, so the emissivity of the hoarfrost as well as that of the surface underneath it must be taken into account when measuring.

Soiling and foreign bodies on the surface

Soiling on the surface of the measuring object such as dust, soot or lubricating oil generally increases the emissivity of the surface. For this reason, measuring dirty objects is generally unproblematic. However, your thermal imager always measures the temperature of the surface, i.e. the dirt, and not the exact temperature of the surface of the measuring object underneath.



- The emissivity of a material depends heavily on the structure of the surface of the material.
- Note the correct emissivity setting according to the covering on the surface of the measuring object.
- Avoid measuring on wet surfaces or surfaces covered with snow or hoarfrost.
- Avoid measuring on loose-lying soiling (distortion of temperature by air pockets).
- When measuring smooth surfaces in particular, be aware of any possible sources of radiation in the vicinity (e.g. sun, heaters etc.).

The measuring environment



1. Ambient temperature

You should also factor in the setting of the reflected temperature (RTC) as well as the emissivity setting (ϵ) so that your thermal imager can calculate the temperature of the surface of the measuring object correctly. In many measurement applications, the reflected temperature corresponds to the ambient temperature (cf. "Radiation", p. 19). You can measure this with an air thermometer, e.g. testo 810.

An accurate setting of the emissivity is particularly important where there is a large difference in temperature between the measuring object and the measuring environment (cf. Fig. 1.2, p. 11).

2. Radiation

Every object with a temperature above absolute zero (0 Kelvin = $-273.15\text{ }^{\circ}\text{C}$) emits infrared radiation. In particular, objects with a large difference in temperature from the measuring object can disrupt the infrared measurement as a result of their own radiation. You should avoid or deactivate sources of interference of this kind wherever possible. By screening the sources of interference (e.g. with canvas or a cardboard box), you will reduce this negative effect on the measurement. If the effect of the source of interference cannot be removed, the reflected temperature does not correspond to the ambient temperature. A globe thermometer or Lambert radiator, for example, is recommended for measuring the reflected radiation in conjunction with your thermal imager (cf. "Determining the temperature of the reflected radiation", p. 27).



Special features of outdoor thermography

The infrared radiation emitted from the clear sky is referred to informally as "cold diffuse celestial radiation". If the sky is clear, "cold diffuse celestial radiation" ($\sim -50\text{ }^{\circ}\text{C}$ to $-60\text{ }^{\circ}\text{C}$) and hot sunlight ($\sim 5500\text{ }^{\circ}\text{C}$) are reflected during the day. In terms of area, the sky outstrips the sun, which means that the reflected temperature in outdoor thermography is usually below $0\text{ }^{\circ}\text{C}$, even on a sunny day. Objects heat up in the sun as a result of absorbing sunlight. This affects the surface temperature considerably – in some cases for hours after exposure to sunlight.

It can be seen in Figure 2.1 (p. 20) that the gutter is shown colder than the house wall on the thermal image. However, both are roughly the same temperature. The image must therefore be interpreted.

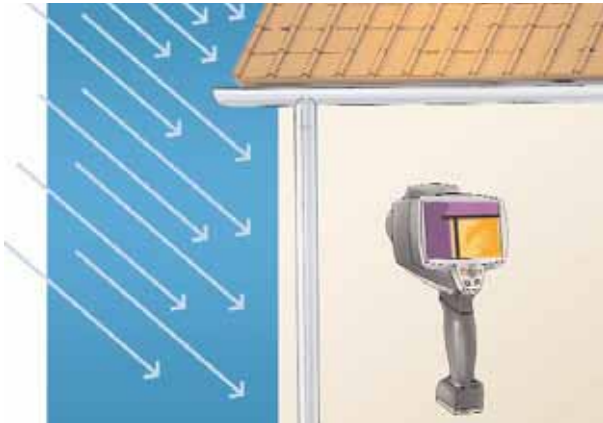

Figure 2.1: Reflection for measurements outdoors

Let us assume that the surface of the gutter is galvanized and has extremely low emissivity ($\epsilon = 0.1$). Only 10% of the long-wave infrared radiation emitted by the gutter is therefore emitted inherent radiation, 90% is reflected ambient radiation. If the sky is clear, "cold diffuse celestial radiation" ($\sim -50\text{ °C}$ to -60 °C) is reflected on the gutter. The thermal imager is set to $\epsilon = 0.95$ and $\text{RTC} = -55\text{ °C}$ to ensure correct measurement of the house wall. Due to the extremely low emissivity and the extremely high reflectance, the gutter is shown too cold on the thermal image. To show the temperatures of both materials correctly on the thermal image, you can change the emissivity of certain areas retrospectively using analyzing software (e.g. with Testo IRSOFT, version 2.0 or higher)



- Please always be aware of the effect of your own personal infrared radiation.
- Change your position during the measurement in order to identify any reflections. Reflections move, thermal features of the measuring object remain in the same place, even if the slant changes.
- Avoid measurements close to very hot or cold objects, or screen these.
- Avoid direct sunlight, including for a few hours before the measurement. Take measurements in the early morning.
- Wherever possible, perform outdoor measurements when it is cloudy.

3. Weather Clouds



A thickly clouded sky offers the ideal conditions for infrared measurements outdoors, as it screens the measuring object from sunlight and "cold diffuse celestial radiation" (cf. "Radiation", p. 19).

Precipitation

Heavy precipitation (rain, snow) can distort the measurement result. Water, ice and snow have high emissivity and are impervious to infrared radiation. In addition, the measurement of wet objects can result in measuring errors, as the surface of the meas-

uring object cools down as the precipitation evaporates (cf. "Surface of the measuring object", p. 16).

Sun

(cf. "Radiation", p. 19)



- Ideally, perform measurements with heavy clouds.
- Also make note of the clouds a few hours before the measurement.
- Avoid heavy precipitation during the measurement.



4. Air

Air humidity

The relative air humidity in the measuring environment should be low enough so that there is no condensation in the air (mist), on the measuring object, on the protection glass or the lens of the thermal imager. If the lens (or protection glass) has misted over, some of the infrared radiation hitting the thermal imager will not be received, as the radiation fails to penetrate fully through the water onto the lens.

Extremely dense mist can affect the measurement, as the water droplets in the transmission path let less infrared radiation through.

Air flows

Wind or a draught in the room can affect the temperature measurement with the thermal imager.

As a result of the heat exchange (convection), the air close to the surface is the same temperature as the measuring object. If it is windy or there is a draught, this layer of air is "blown away" and replaced by a new layer of air that has not yet adapted to the temperature of the measuring object. As a result of convection, heat is taken away from the warm measuring object or absorbed by the cold measuring object until the temperature of the air and the surface of the measuring object have adjusted to each other. This effect of the heat exchange increases the greater the temperature difference between the surface of the measuring object and the ambient temperature.

Air pollution

Some suspended matter such as dust, soot and smoke, for example, as well as some vapours have high emissivity and are barely transmissive. This means that they can impair the measurement, as they emit their own infrared radiation that is received by the thermal imager. In addition, only some of the infrared radiation of the measuring object can penetrate through to the thermal imager, as it is scattered and absorbed by the suspended matter.



- Never perform measurements in thick mist or above water vapour.
- Do not perform measurements when air humidity is condensing on the thermal imager (cf. "Wetness, snow and hoarfrost on the surface", p. 17).
- Avoid wind and other air flows during the measurement wherever possible.
- Note the speed and direction of air flows during the measurement and factor these data into your analysis of the thermal images.
- Do not perform measurements in heavily polluted air (e.g. just after dust has been stirred up).
- Always measure with the smallest possible measuring distance for your measurement application in order to minimize the effect of any possible suspended matter in the air.



5. Light

Light or illumination do not have a significant impact on measurement with a thermal imager. You can also take measurements in the dark, as the thermal imager measures long-wave infrared radiation. However, some light sources emit infrared heat radiation themselves and can thus affect the temperature of objects in their vicinity. You should therefore not measure in direct sunlight or near a hot light bulb, for example. Cold light sources such as LEDs or neon lights are not critical, as they convert the majority of the energy used into visible light and not infrared radiation.

2.2 Determining ϵ and RTC in practical applications

To determine the emissivity of the surface of the measuring object, you can, for example:

- refer to the emissivity given in a table (cf. "Emissivity table", p. 50).

Caution:

Values in emissivity tables are only ever guideline values. The emissivity of the surface of your measuring object may therefore differ from the specified guideline value.

- determine the emissivity by means of a reference measurement with a contact thermometer (e.g. with the testo 905-T2 or testo 925) (cf. "Method using a contact thermometer", p. 25).
- determine the emissivity by means of a reference measurement with the thermal imager (cf. "Method using the thermal imager", p. 26).

Determining the emissivity by means of a reference measurement

1. Method using a contact thermometer

First measure the temperature of the surface of the measuring object with a contact thermometer (e.g. testo 905-T2 or testo 925). Now measure the temperature of the surface of the measuring object with the thermal imager with a preset emissivity of one. The difference between the temperature values measured by the contact thermometer and the thermal imager are the result of the emissivity being set too high. By gradually lowering the emissivity setting, you can change the measured temperature until it corresponds to the value

obtained in the contact measurement. The emissivity then set corresponds to the emissivity of the surface of the measuring object.

2. Method with the thermal imager

First stick a piece of emissivity adhesive tape (e.g. heat-resistant emissivity adhesive tape from Testo) to your measuring object. After waiting a short time, you can measure the temperature of the surface of the measuring object in the taped-off area using your thermal imager with a set emissivity for the adhesive tape. This temperature is your reference temperature. Now regulate the emissivity setting until the thermal imager measures the same temperature in the area which is not taped as the reference temperature just measured. The emissivity now set is the emissivity of the surface of the measuring object.

As an alternative to the emissivity adhesive tape, you can also:

- coat the measuring object with a coating or paint with a known emissivity.
- coat the measuring object with a thick layer (> 0.13 mm) of heat-resistant oil ($\epsilon \approx 0.82$).
- coat the measuring object with a thick layer of soot ($\epsilon \approx 0.95$).

● Caution:

Always follow the operating instructions for the measuring object!



- When coating or bonding the measuring object, take account of the fact that the coating or adhesive tape first has to adjust to the temperature of the object before a correct measurement is possible.

Determining the temperature of the reflected radiation

Once you have eradicated all the possible sources of interference that could affect your measurement, the temperature of the reflected infrared radiation is the same as the ambient temperature. You can measure the ambient temperature with an air thermometer, e.g. testo 810, and enter the RTC in your thermal imager on the basis of this.

However, if sources of radiation are present in the measuring environment, you should determine the temperature of the reflected radiation to ensure an accurate measurement result.

Measurement of reflected temperature using an (improved) Lambert radiator

A Lambert radiator is an object that reflects incident radiation with the optimum diffusion, in other words equally strongly in all directions.

You can measure the temperature of the reflected radiation on a Lambert radiator using the thermal imager. A piece of aluminium

foil crumpled and then unfolded again is a suitable substitute for a Lambert radiator for this purpose. The foil has high reflectance and thanks to the crumpled structure, the diffuse reflection of the radiation is near-perfect (cf. Fig. 2.3, right side of aluminium foil, p. 32).

To measure the temperature of the reflected radiation, place the Lambert radiator near the measuring object or ideally on the surface of the measuring object. Then measure the temperature at the radiator with emissivity set to one. The imager will now calculate the temperature of the incident radiation. You can now input this value as the RTC in your thermal imager and measure the temperature at the measuring object with the set emissivity for the surface of your measuring object.

2.3 Sources of error in infrared measurement

The following factors can distort the result of your infrared measurement:

- Incorrect emissivity setting
 - ⇒ Determine and set the correct emissivity (cf. "Determining the emissivity by means of a reference measurement", p. 25).
- Incorrect RTC setting
 - ⇒ Determine and set the reflected temperature (cf. "Determining the temperature of the reflected radiation", p. 27).
- Unclear thermal image
 - ⇒ Focus your thermal image in situ, as the sharpness cannot be changed once the picture has been taken.
- Measuring distance is too long or too short
- Measurement taken with unsuitable lens
- Measuring spot too big
 - ⇒ When taking the measurement, note the minimum focussing distance of your thermal imager.
 - ⇒ As when taking an ordinary photograph, use the telephoto lens and wide-angle lens appropriately.
 - ⇒ Choose a small measuring distance where possible.
- Faults in the transmission path (e.g. air pollution, covers etc.)
- Effect of external sources of radiation (e.g. light bulbs, sun, heaters etc.)
- Misinterpretation of thermal image due to reflection
 - ⇒ Avoid measuring where there are sources of interference.
 - ⇒ Deactivate or screen sources of interference wherever possible, or factor their influence into the analysis of the thermal image.
- Quick change of ambient temperature
 - ⇒ If there are changes in ambient temperature from cold to hot, there is the risk of condensation on the lens.
 - ⇒ Wherever possible, use thermal imagers with temperature-stabilized detectors.
- Misinterpretation of the thermal image due to lack of knowledge of the design of the measuring object
 - ⇒ The type and design of the measuring object should be known.
 - ⇒ Also use real images (photos) wherever possible to interpret the thermal images.

Measurements on glass

The human eye can look through glass, but glass is impervious to infrared radiation. The thermal imager therefore only measures the surface temperature of the glass and not the temperature of the materials behind it (cf. Fig. 2.2). For short-wave radiation such as sunlight, however, glass is transmissive. You should therefore note that sunlight shining through the window, for example, could heat your measuring object.

Glass is also a reflective material. Be aware therefore of specular reflection when measuring on glass (cf. "Specular reflection", p. 31).

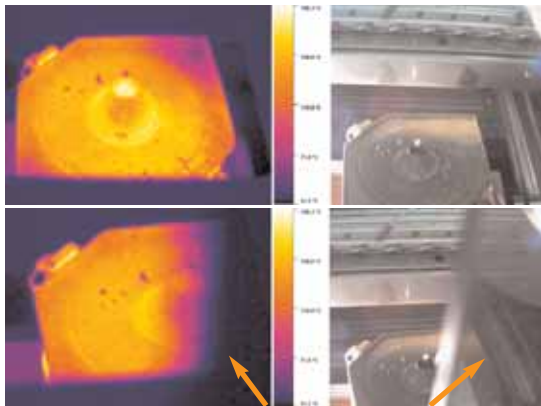

Glass pane inserted in front of the measuring object

Figure 2.2: Measuring on glass

Measurements on metal

Metals, particularly those with a shiny surface, are strong reflectors of long-wave infrared radiation. They have extremely low emissivity, which changes with the temperature (cf. "Coloured body radiators", p. 40). Measuring the temperature of these with a thermal imager therefore presents problems. Apart from regulating the emissivity, the correct setting of the reflected temperature (cf. "Determining the temperature of the reflected radiation", p. 27) is particularly important. Also note the advice given about specular reflection (cf. "Specular reflection", p. 31).

If metals are painted measurement is unproblematic, as paints generally have high emissivity. However, you must again be aware of reflections of the ambient radiation here.

Specular reflection

A clearly visible specular reflection is often an indicator of a highly reflective surface, i.e. a surface with low emissivity. However, highly specular is not always the same as highly reflective. For example, specular reflections of the ambient radiation can be seen on the thermal image of a painted surface (e.g. silhouette of person taking the reading), even though paint generally has high emissivity ($\epsilon \approx 0.95$). Conversely, the outlines of reflected objects in the measuring environment cannot be seen on the thermal image of a sandstone wall for example, even though sandstone has low emissivity ($\epsilon \approx 0.67$).

Whether the ambient radiation is reflected specularly in clear outlines therefore does not depend primarily on the emissivity but on the structure of the surface.

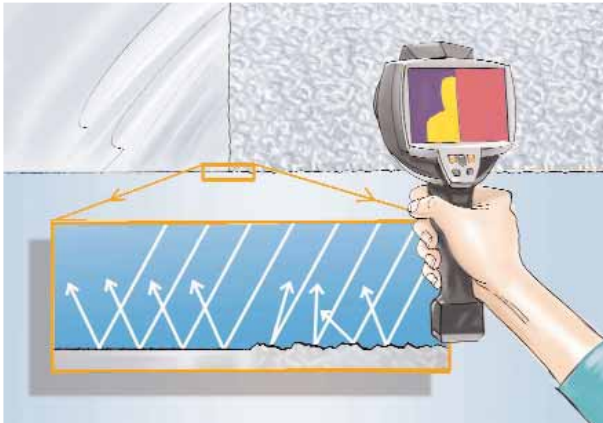

Figure 2.3: Specular and diffuse reflection

All radiation is always reflected at the same angle at which it hits the surface. This means that the following rule of thumb always applies: angle of incidence = angle of reflection. This is clearly recognisable in Figure 2.3 in the enlarged cross-section of the smooth half of the aluminium foil (left-hand side). Here the infrared radiation of the person taking the reading is reflected in the same form in which it hit the surface (specular reflection).

Of course the rule angle of incidence = angle of reflection also applies to the infrared radiation hitting the crumpled aluminium foil (right-hand side). Here, however, the infrared rays fall on partial

areas at different angles to each other rather than on a flat surface. As on a Lambert radiator, they are therefore reflected in different directions. This diffuse reflection means that no outlines of the sources of reflected infrared radiation can be seen. The reflection on the entire crumpled side of the aluminium foil is a mixture of the infrared radiation of the two reflected sources of radiation (person taking the reading and background behind the person taking the reading).

- Highly specular does not always mean highly reflective.
- Please always be aware of the effect of your own personal infrared radiation.
- Surfaces on which no specular reflection can be detected can also have high reflectance.
- Measure smooth surfaces from different angles and directions in order to establish which of the irregularities in the temperature distribution are attributable to reflection and which are ascribable to the measuring object.



2.4 The optimum conditions for infrared measurement

Stable ambient conditions above all are important for infrared measurement. This means that the climate and objects in the measuring environment as well as any other influences should not change during the measurement. This is the only way to assess possible sources of interference and document them for later analysis.

For measurements outdoors, the weather conditions should be stable and the sky cloudy in order to screen the measuring object from both direct sunlight and "cold diffuse celestial radiation". You must also be aware that measuring objects may still be heated from previous exposure to sunlight due to their heat storage capacity.

The ideal measuring conditions are:

- Stable weather conditions;
- Cloudy sky before and during the measurement (for measurements outdoors);
- No direct sunlight before and during the measurement;
- No precipitation;
- Surface of measuring object dry and clear of thermal sources of interference (e.g. no foliage or chips on the surface);
- No wind or draught;
- No sources of interference in the measuring environment or transmission path;
- The surface of the measuring object has high emissivity that is known exactly.

For building thermography, a difference of at least 15 °C between the inside and outside temperature is recommended.

2.5 The perfect thermal image

When taking a thermal image, you should pay attention to two things in particular:

- choosing the right subject area, and
- focussing the thermal image correctly on the area relevant to the measurement.

As with a normal digital picture, you cannot change either the subject area or the focus of the image once the thermal image has been saved.

To obtain a perfect thermal image, you can make the following changes in your thermal imager and in the analyzing software (e.g. Testo IRSof):

- Change the emissivity and the reflected temperature compensation (RTC) setting.
This can also be done point-by-point or in sections with professional analyzing software such as Testo IRSof 2.0, for example.
- Choose an appropriate colour palette (e.g. iron, rainbow etc.).
Depending on the colour palette, you will get a high-contrast, easy to interpret thermal image.
- Adjust the temperature scale manually.
This is how you can improve the temperature grading or colour grading of your thermal image (cf. Fig. 2.4).

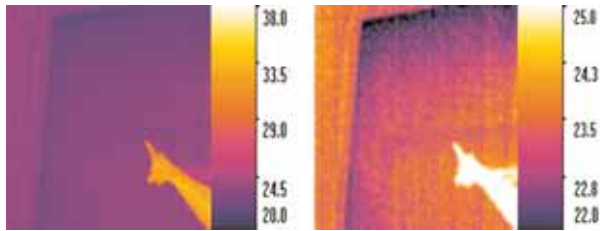

Figure 2.4: Adjusting the temperature scale

- The design of your measuring object should be known in order to be able to correctly identify thermal features.
- Use a thermal imager with a built-in digital camera so that you can use real pictures for analysis at a later date.
- Note all ambient conditions and measure and document these where necessary for the subsequent analysis of the thermal images.

Observe the following tips for taking the thermal image:

- Factor in, prevent or screen all sources of interference.
- The surface of the measuring object should be clear of optical and thermal sources of interference.
Where possible, remove covers and objects causing interference from the environment.
- Change your position when taking the measurement in order to identify any reflections.
Reflections move, thermal features of the measuring object remain in the same place, even if the slant changes.
- Your measuring spot should never be bigger than your measuring object.
- Keep the measuring distance as small as possible.
- Use a lens appropriate to your measurement task.
- For exact measurement of details, it is recommended to use a stand.

3 Appendix

3.1 Glossary of thermography

A

Absolute zero

Absolute zero is $-273.15\text{ }^{\circ}\text{C}$ ($0\text{ Kelvin} = -459.69\text{ }^{\circ}\text{F}$). No body emits thermal energy below absolute zero; this means that they do not emit any infrared radiation.

Absorption

When electromagnetic infrared radiation hits an object, the object absorbs some of this energy. The absorption of infrared radiation means that the object heats up. Warmer objects emit more infrared radiation than colder objects. The absorbed infrared radiation is thus converted into emitted infrared radiation (radiating from the object). The absorptivity therefore corresponds to the emissivity.

The incident infrared radiation on the object that is not absorbed is reflected and/or transmitted (let through).

B

Black body radiator

An object that absorbs all of the energy from the incident infrared radiation, converts it into its own infrared radiation and emits it in full. The emissivity of black radiators is exactly one. There is therefore no reflection or transmission of the radiation. Objects with properties of this nature do not occur in the field.

Devices for calibrating thermal imagers are known as black body radiators. However, their emissivity is only just under one ($\epsilon > 0.95$).

C

Calibration

Procedure where the readings of an instrument (actual values) and readings of a reference instrument (nominal values) are determined and compared. The result provides clues as to whether the actual readings of the instrument are still within a permissible limit/tolerance range. Unlike in an adjustment, the identified deviation from the actual reading is merely documented in a calibration and not adjusted to the nominal reading. The intervals at which a calibration is to be performed depends on the respective measurement tasks and requirements.

Celsius [$^{\circ}\text{C}$]

Temperature unit. Under normal pressure, the zero point of the Celsius scale ($0\text{ }^{\circ}\text{C}$) is the temperature at which water freezes. Another fixed point for the Celsius scale is the boiling point of water at $100\text{ }^{\circ}\text{C}$.

$$^{\circ}\text{C} = ({}^{\circ}\text{F} - 32)/1.8 \text{ or } ^{\circ}\text{C} = \text{K} - 273.15.$$

Coldspot and hotspot

The coldest spot of an area on the thermal image is referred to as a "coldspot", the hottest spot as a "hotspot".

Using the function "Auto Hot/Cold Spot Recognition", you can display these two spots directly on your thermal image in the

imager display. This function is also available in many of the analyzing software packages. e.g. in Testo IRSofT 2.0. In this software you can also display these two spots for any areas of the thermal image you wish to define.

Coloured body radiator

An object with an emissivity smaller than one that is dependent on the temperature and fluctuates with it. Most metals are coloured radiators, which is why the emissivity of aluminium, for example, increases when it is heated ($\epsilon = 0.02$ at 25 °C, $\epsilon = 0.03$ at 100 °C).

Colour palette

Selection of colours for thermal image in the imager (e.g. colour palette "rainbow", "iron", "grey scales"). The contrasts of the thermal images can be shown with varying quality depending on the measurement task and the colour palette set. The colour palette can also be set individually using analyzing software (e.g. Testo IRSofT) after the thermal image has been saved. Bear in mind the interpretability of your thermal image when choosing the colour palette. Red and yellow colours are intuitively associated by the viewer with heat, green and blue colours with cold.

Condensation

Transition of a substance from the gaseous to the liquid state. Air humidity can condense on surfaces if the surface temperature and therefore the temperature of the air on the surface is lower than

the surrounding air temperature or if it is at the dewpoint temperature.

Conduction

Heat conduction. Transfer of thermal energy between neighbouring particles. Energy is always transferred from the warmer to the colder particle. Unlike convection, there is no transport of the particles in conduction.

Convection

Transport of heat whereby thermal energy moves from one body, fluid or gas to another body, fluid or gas as a result of the transport of particles.

D

Detector

The detector receives the infrared radiation and converts it into an electrical signal. The size of a detector is specified in pixels.

Dewpoint/dewpoint temperature

Temperature at which water condenses. At dewpoint temperature, the air is saturated with more than 100% water vapour. Once the air cannot absorb any more water vapour, condensate forms.

E

Emissivity (ϵ)

A measure of the ability of a material to emit (give off) infrared radiation. The emissivity varies according to the surface properties, the material and, for some materials, also according to the temperature of the object.

Equalization period

The time that the imager requires to adjust to the ambient temperature of the location.

Temperature-stabilized detectors such as that in the testo 880 thermal imager have a comparatively short equalization period.

F

Fahrenheit [$^{\circ}\text{F}$]

Unit of temperature that is primarily used in North America.

$$^{\circ}\text{F} = (^{\circ}\text{C} \times 1.8) + 32.$$

Example of 20 $^{\circ}\text{C}$ in $^{\circ}\text{F}$: $(20 \text{ }^{\circ}\text{C} \times 1.8) + 32 = 68 \text{ }^{\circ}\text{F}$.

FOV (field of view)

Field of view of the thermal imager. It is specified as an angle (e.g. 32 $^{\circ}$) and defines the area that can be seen with the thermal imager. The field of view is dependent on the detector in the thermal imager and on the lens used. Wide-angle lenses have a large field of view for the same detector, telephoto lenses (e.g. Testo 12 $^{\circ}$ telephoto lens) a small field of view.

G

Grey body radiator

Allmost all naturally occurring objects are described as "grey body radiators" or "real radiators". Unlike black body radiators, grey body radiators never absorb all of the incident infrared radiation. With a grey body radiator, some of the incident radiation is always reflected by the surface and sometimes even transmitted (let through). The emissivity of a grey body radiator is therefore always smaller than one.

H

Hotspot

Cf. "Coldspot and hotspot", p. 39)

I

Ideal radiator

Cf. "Black body radiator", p. 38.

Infrared radiation

Infrared radiation is electromagnetic heat radiation. Every object with a temperature above the absolute zero point (0 Kelvin = -273.15 $^{\circ}\text{C}$) emits infrared radiation. Infrared radiation covers the wavelength range from 0.75 μm up to around 1,000 μm (= 1 mm) and therefore borders on the wavelength range for light (0.38 to 0.75 μm). Thermal imagers often measure the long-wave infrared radiation in the range from 8 μm to 14 μm (like the testo 880, for

example), as the atmosphere in this wavelength range is extremely permeable to infrared radiation.

IFOV_{geo} (Instantaneous Field of View)

Geometric resolution (spatial resolution). Measure of the ability of a detector, in conjunction with the lens, to resolve details. The geometric resolution is specified in mrad (= milliradian) and defines the smallest object that, depending on the measuring distance, can still be depicted on the thermal image. On the thermal image, the size of this object corresponds to one pixel.

IFOV_{meas} (Measurement Instantaneous Field of View)

Designation of the smallest object for which the temperature can be accurately measured by the thermal imager. It is 2 to 3 times larger than the smallest identifiable object (IFOV_{geo}).

The following rule of thumb applies: $IFOV_{meas} \approx 3 \times IFOV_{geo}$.

IFOV_{meas} is also known as the measuring spot.

Isotherms

Lines of the same temperature. You can display isotherms using analyzing software (e.g. Testo IRSofT). In the process, all spots in the thermal image with temperature values within a defined range are marked in colour.

K

Kelvin [K]

Temperature unit.

0 K corresponds to absolute zero (-273.15 °C). The following applies accordingly: $273.15 \text{ K} = 0 \text{ °C} = 32 \text{ °F}$.

$K = \text{°C} + 273.15$.

Example of 20 °C in K: $20 \text{ °C} + 273.15 = 293.15 \text{ K}$.

L

Lambert radiator

A Lambert radiator is an object that reflects incident radiation with the optimum diffusion; in other words the incident radiation is reflected with equal strength in all directions.

You can measure the temperature of the reflected radiation on a Lambert radiator using the thermal imager.

Laser measuring spot marking

A laser supports homing in on the measuring surface (a red dot is projected onto the measuring object). The laser sighting and the centre of the image do not correspond exactly as they are on different optical axes. The laser dot is therefore not suitable for marking exact locations that were aimed at in the display using the crosshairs. It only serves as a guide.

Caution:

Laser class 2: never direct the laser at persons or animals and never look into the laser! This can damage eyes!

Lenses

The size of the field of view of the thermal imager and in turn the size of the measuring spot change according to the lens used. A wide-angle lens (e.g. 32° standard lens for the testo 880) is particularly suitable if you want an overview of the temperature distribution across a large surface. You can use a telephoto lens (e.g. Testo 12° telephoto lens) to measure small details accurately, even from a longer distance.

M

Measuring spot

Cf. "IFOV_{meas}", p. 44.

N

NETD (Noise Equivalent Temperature Difference)

Key figure for the smallest possible temperature difference that can be resolved by the imager. The smaller this value, the better the measuring resolution of the thermal imager.

R

Real body

Cf. "Grey body radiator", p. 43.

Reflectance (ρ)

The ability of a material to reflect infrared radiation. The reflectance depends on the surface properties, the temperature and the type of material.

Refresh rate

Specification in hertz of how often per second the displayed image is refreshed (e.g. 9 Hz/33 Hz/60 Hz). A refresh rate of 9 Hz means that the thermal imager updates the thermal image in the display nine times per second.

Relative humidity (%RH)

Indicator in percentage of how saturated with water vapour the air is. For example, at 33%RH the air only contains about 1/3 of the maximum volume of water vapour that the air could absorb at the same temperature and the same air pressure. At an air humidity in excess of 100%, condensate starts to form as the air is fully saturated and cannot take any more moisture. The gaseous water vapour in the air therefore turns to liquid. The hotter the air, the more water vapour it is able to absorb without condensation occurring. Condensation therefore always occurs first on cold surfaces.

RTC (Reflected Temperature Compensation)

With real bodies, some of the heat radiation is reflected. This reflected temperature must be factored into the measurement of objects with low emissivity. Using an offset factor in the imager, the reflection is calculated out and the accuracy of the temperature measurement is thus improved. This is generally done by means of a manual input into the imager and/or via the software.

In most cases, the reflected temperature is identical to the ambient temperature. If the infrared radiation from sources of interfer-

ence is reflected on the surface of the measuring object, you should determine the temperature of the reflected radiation (e.g. using a globe thermometer or a Lambert radiator). The reflected temperature has only little effect on objects with very high emissivity.

T

Temperature

Variable for the energy inherent within a body.

Thermal image

Image that shows the temperature distributions of the surfaces of objects using different colours for different temperature values. Thermal images are taken with a thermal imager.

Thermal imager

Camera that measures infrared radiation and converts the signals into a thermal image. Using the thermal imager, temperature distributions of surfaces can be shown that are not visible to the human eye. Typical applications are found for example in building thermography and in electrical and industrial thermography.

Thermography

Imaging procedure using measuring technology that visualizes heat radiation or the temperature distributions of object surfaces using a thermal imager.

Thermogram

Cf. "Thermal image", p. 48.

Transmittance (T)

Measure of the ability of a material to allow infrared radiation to pass through it. It depends on the thickness and type of the material. Most materials are not permeable to long-wave infrared radiation.

Two-point measurement

The two-point measurement has two crosshairs in the imager display with which individual temperatures can be read off.

3.2 Emissivity table

The following tables serves as a guide for adjusting the emissivity for infrared measurement. It gives the emissivity ϵ of some of the more common materials. As the emissivity changes with the temperature and surface properties, the values shown here should be regarded merely as guidelines for measuring of temperature conditions or differences. In order to measure the absolute temperature value, the exact emissivity of the material must be determined.

Material (material temperature)	Emissivity
Aluminium, bright rolled (170 °C)	0.04
Aluminium, not oxidized (25 °C)	0.02
Aluminium, not oxidized (100 °C)	0.03
Aluminium, heavily oxidized (93 °C)	0.20
Aluminium, highly polished (100 °C)	0.09
Cotton (20 °C)	0.77
Concrete (25 °C)	0.93
Lead, rough (40 °C)	0.43
Lead, oxidized (40 °C)	0.43
Lead, grey oxidized (40 °C)	0.28
Chrome (40 °C)	0.08
Chrome, polished (150 °C)	0.06
Ice, smooth (0 °C)	0.97
Iron, emery-ground (20 °C)	0.24
Iron with casting skin (100 °C)	0.80
Iron with rolling skin (20 °C)	0.77
Gypsum (20 °C)	0.90
Glass (90 °C)	0.94
Granite (20 °C)	0.45

Material (material temperature)	Emissivity
Rubber, hard (23 °C)	0.94
Rubber, soft, grey (23 °C)	0.89
Cast iron, oxidized (200 °C)	0.64
Wood (70 °C)	0.94
Cork (20 °C)	0.70
Radiator, black, anodized (50 °C)	0.98
Copper, slightly tarnished (20 °C)	0.04
Copper, oxidized (130 °C)	0.76
Copper, polished (40 °C)	0.03
Copper, rolled (40 °C)	0.64
Plastics: PE, PP, PVC (20 °C)	0.94
Paint, blue on aluminium foil (40 °C)	0.78
Paint, black, matt (80 °C)	0.97
Paint, yellow, 2 coats on aluminium foil (40 °C)	0.79
Paint, white (90 °C)	0.95
Marble, white (40 °C)	0.95
Brickwork (40 °C)	0.93
Brass, oxidized (200 °C)	0.61
Oil paints (all colours) (90 °C)	0.92 to 0.96
Paper (20 °C)	0.97
Porcelain (20 °C)	0.92
Sandstone (40 °C)	0.67
Steel, heat-treated surface (200 °C)	0.52
Steel, oxidized (200 °C)	0.79
Steel, cold-rolled (93 °C)	0.75 to 0.85
Clay, burnt (70 °C)	0.91
Transformer paint (70 °C)	0.94
Brick, mortar, plaster (20 °C)	0.93
Zinc, oxidized	0.1

All these products are supplied by **unitemp**[®]

Contact us to request any additional information on these or any of our other product ranges, or to place an order.

Johannesburg:

Unitemp cc. P.O Box 1035,
Isando, 1600

Street Address:
7 Vuurslag Street, Spartan Ex7,
Kempton Park

Tel: ++27 11 392 5989
Fax: ++27 11 392 5235

Cape Town:

Unitemp cc. P.O Box 24110,
Lansdowne, Cape Town, 7779

Street Address:
47 Flamingo Crescent, Lansdowne,
Cape Town, 7780

Tel: ++27 21 762 8995
Fax: ++27 21 762 8996

sales@unitemp.com

www.unitemp.com

[find more information here](#)